



MATRIX™
Panel-Based System

AIS



ENTER THE **MATRIX**

Take a seat and experience a new dimension of collaboration and productivity. Matrix creates sophisticated, cost-efficient, and super-flexible work spaces that stack up and stand the test of time—in open plan areas, private offices, reception areas, conference rooms, and beyond.



PANEL-BASED PERFECTION

Matrix isn't your ordinary panel-based system. Not even close. Its modular foundation lets the system grow and evolve. Today's workstation can be tomorrow's private office. A setting for four can expand to accommodate ten. Matrix doesn't just deal with change. It thrives on it.

STACK THE BENEFITS IN YOUR FAVOR

Matrix's stackable design lets you build the environment that's just right for the people, place, need, and technology. And, with plenty of tile options to choose from—fabric acoustical, laminate, whiteboard, tool rail, embossed steel, perforated steel, painted steel, and glass—you can choose Matrix's finish, then swap it out for another on a whim.





GO WITH THE WORKFLOW

The workplace can't afford to be a one-trick pony. It needs different places for different purposes. That's why Matrix's statement of line is remarkably broad. It fosters a high level of flow between departments—whether it's buzzing and collaborative or it requires more peace and quiet.



DESIGNED TO INTEGRATE

With over a decade of proven performance, Matrix seamlessly coordinates with our Calibrate® Series, Day-to-Day™ Tables, L Series, and more. It also shares surfaces and finishes with Aloft® and Oxygen® Desking Systems. Coordinated beyond compare, Matrix sets a confident tone and empowers everyone's best work.



STRONG AS STEEL

Need a system you can reconfigure time and again with ease? Good, because Matrix is one of the strongest full-steel-frame systems out there, with a foundation that doesn't quit on the job. Sophisticated on the outside. Strong on the inside.

POWERFUL PANELS

The Matrix electrical system has ample capacity and substantial design flexibility. Matrix provides electrical and data cabling holes at every 8 inches of height, forming up to 10 laterally continuous raceway channels on an 82 inch high panel. Electrical and data may be run through the panel frames at every height and multiple powerways can be positioned from the bottom of the panel up to 114 inches in height, providing extensive cabling capacity and power access placement options. Power and data can be consolidated in a single power tile, offering up to 3 duplexes and 6 Data Jack Housings in a single location.

- Powerways providing access to an 8 wire or 10 wire electrical system may be mounted at any height from base to beltline or above. Every 8 inch power access tile can accommodate two powerways stacked to allow access for up to four duplex outlets and/or data jack housings.
- A true unimpeded "lay in" topcap channel accommodates up to 16 category 6 cables in addition to the internal raceways. Stack frames may be retrofit over lay in channel without removing existing cables. Matrix sets a new industry standard for electrical and data capacity, flexibility, and access.
- Internal covered cable compartments can be ordered to separate secure data lines from non-secure lines.
- Triple channel powerpoles can each accommodate multiple feeds and dozens of data cables.
- Matrix access tiles have a universal data housing interface and can accommodate any manufacturers' data device housings, including Hubbell™, Ortronics™, Amp™, Leviton™, and others.



A FULL MATRIX OF CONFIGURATIONS

Matrix serves a world of purposes, but don't take our word for it. Take a look at some of our favorite configurations. Then go dream up one of your own.



QUALITY & DETAILS



Tapered Leg



A-Leg



N-Leg



Reverse Knife Edge



Calibrate® Series storage integrates effortlessly with Matrix



Specify Calibrate® Series storage on feet for a lighter look

The Matrix system offers many choices, ensuring workstations can meet the unique needs of users. Whether it's a variety of worksurface supports or integration with our Calibrate Series laminate solutions, it's easy to design highly functional, highly personal work environments with Matrix.



Matrix Fit

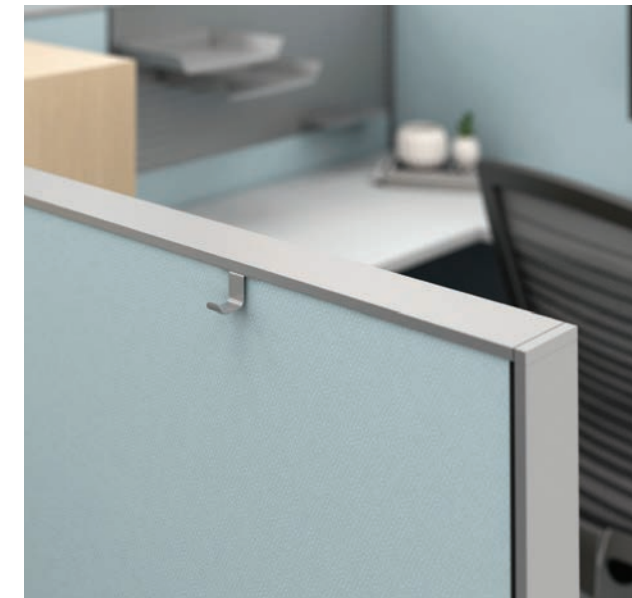

Coat Hook on Panel



Rectangular Pull



Bar Pull



L-Pull

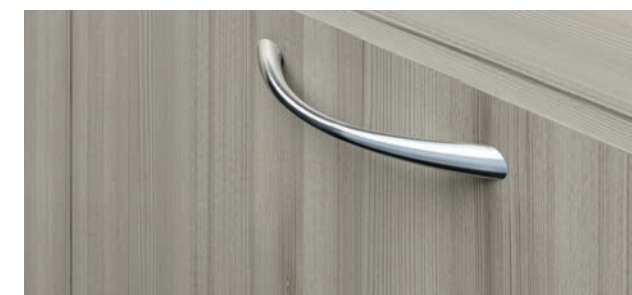

Loop Pull

EXPLORE THE OFFERING

Frames

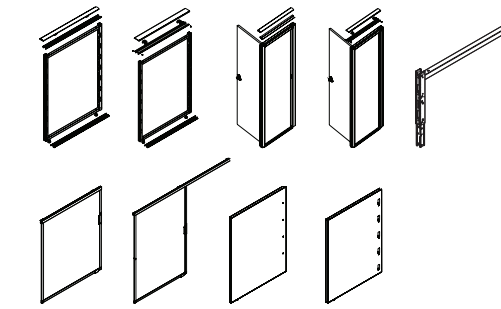

Connectors

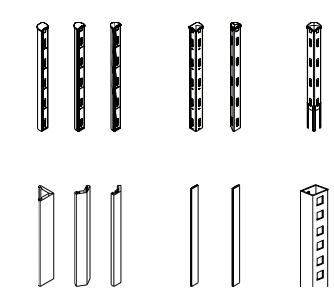

Electrical

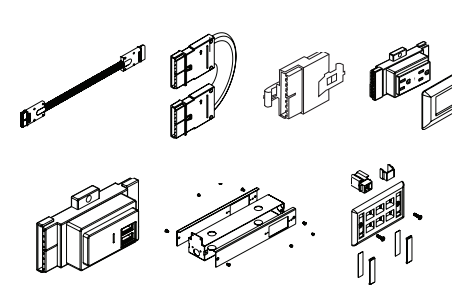

Tiles

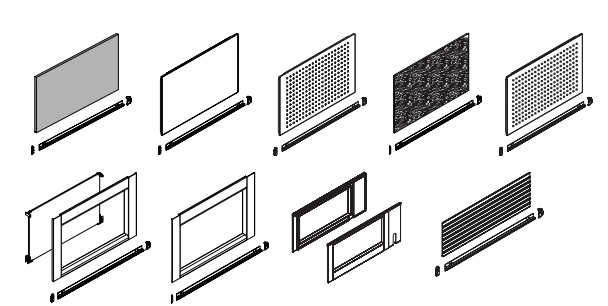

Support

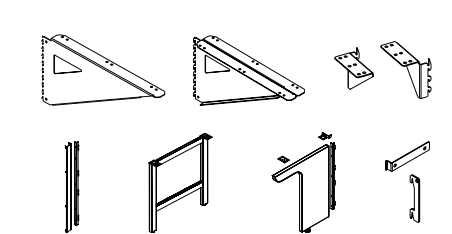

Storage

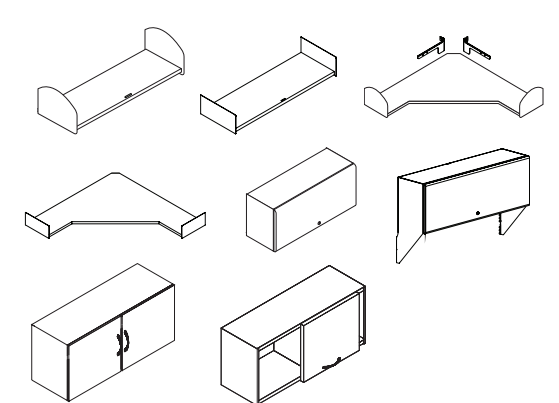

Accessories

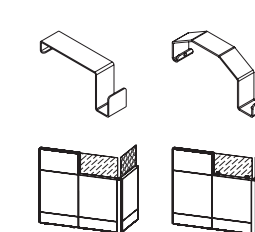

Visit ais-inc.com/products/matrix to view the complete statement of line and learn more.

MATERIALS & FINISHES

Laminates*

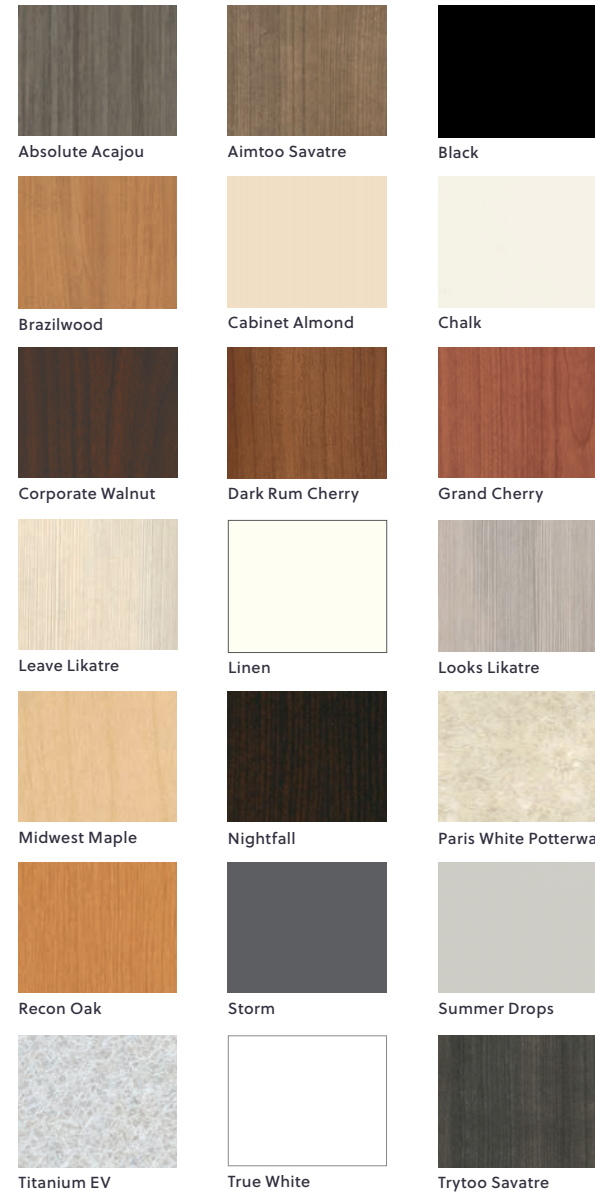

*Laminates can be applied to worksurfaces and panels.

Please contact your AIS Representative to request samples for viewing before specifying. The colors, materials and finishes featured within our printed and electronic literature may vary due to the printing processes and/or viewing screens used.

Paints



Worksurfaces

Many different worksurfaces are available.

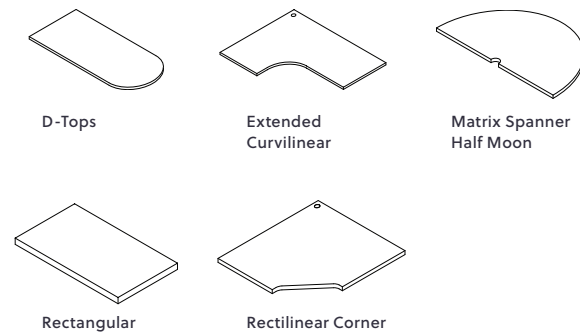

FEATURED FABRICS & FINISHES

Cover

Calibrate & Worksurfaces: Looks Likatre **Matrix Trim:** Lite Silver **Glass:** Grey **Matrix Tiles (Interior):** Mayer Fedora – Indigo **Matrix Tiles (Exterior):** Guilford of Maine Whisper – Cloud **Natick Seating:** Grey Graduated Striped Mesh back and LUUM Navigate – Pumice Upholstered Seats **Volker Cubes:** Brentano Dimension – Flatland

Page 2-3

Calibrate Storage: Aimtoo Savatre **Matrix Trim:** Satin White **Glass:** Frosted **Matrix Tiles:** AIS Engage – Cape Cod Chatham **Bolton Seating:** Momentum Crossing – Alabaster

Page 4-5

Matrix Laminate Tiles: Looks Likatre **Calibrate Storage:** Looks Likatre **Glass:** Grey **Matrix Trim and Overheads:** Graphite Sky **Matrix Tiles:** AIS Avenue Park Place

Pages 6-7

Calibrate Storage: Looks Likatre and True White **Matrix Trim and Legs:** Innertone **Matrix Tiles:** AIS Cape Cod – Harwich **Storage Cushions:** LoomSource Enamour – Daydream **Bolton Seating:** Fully Upholstered in LUUM Navigate – Pumice **Volker Cubes:** Maharam Entwine – Quench

Availability of materials shown above may vary due to manufacturers' lifecycle management. Some materials shown are standard on AIS and some are COM. Please check with AIS to confirm availability and pricing.

National Showrooms:

Leominster
AIS Headquarters
25 Tucker Drive
Leominster, MA 01453

New York
AIS New York
257 Park Avenue South
New York, NY 10010

GSA Sales
GSA Contract GS-29F-0006K
FSC Group 71
Part 1 Office Furniture

Chicago
The Merchandise Mart
Suite 1086
Chicago, IL 60654

Washington, D.C.
AIS Washington, D.C.
1400 I St., NW, Suite 750
Washington, D.C. 20005

For additional information on AIS:
Dealer Showrooms, Representative Directory, Project Case Studies, Online Catalog & Product Showcase
Visit: ais-inc.com

For additional images: <http://imagelibrary.ais-inc.com/>

800.434.7400 | 978.562.7500 | www.ais-inc.com | info@ais-inc.com | 10/2019 | MXBR